Plasma Metrology System

Hercules[®] PMX

Hercules[®] C

Hercules[®] N

Operator Manual

plasmatrex
plasma metrology experience

Edition: January 2010

0.1 LEGAL INFORMATION

European Patent EP 0 719 077 B1

US Patent 08 / 529 020

Japanese Patent 2872954

Other patents are pending.

Reproduction, transfer, distribution or storage of part or all of the contents in this document in any form without the prior written permission of Plasmatrix is prohibited.

Applied Materials[®], DPS[®], DPS+, eMAX, MxP, MxP+, Super-E, and HART are trademarks of Applied Materials, Inc..

Lam[®], TCP[®], Rainbow, and LamStation are trademarks of Lam Research Corporation.

TEL is a trademark of Tokyo Electron Limited.

Plasmatrix and Hercules[®] are trademarks of Plasmatrix GmbH.

Microsoft and Windows are trademarks of Microsoft Corporation.

Registered names, trademarks, etc., used in this manual, even when not specifically market as such, are not to be considered unprotected by law.

Plasmatrix GmbH 2010 - All rights reserved. Subject to technical alternations!

Edition: January 2010

Plasmatrix GmbH

Schwarzschildstr. 3

D-12489 Berlin

Germany

phone: +49 30 63 92 50 40

fax: +49 30 63 92 50 41

plasmatrix.com

info@plasmatrix.com

0.2 WARRANTY

Plasmetrex GmbH believes the information in this document is accurate. The document has been carefully reviewed for technical accuracy. In the event that technical or typographical errors exist, Plasmetrex GmbH reserves the right to make changes without prior notice. The reader should consult Plasmetrex GmbH if errors are suspected. In no event shall Plasmetrex GmbH be liable for any damages arising out of, or related to this document or the information contained therein.

Furthermore disassembling of Hercules® system or sensor head or parts of them will void the warranty.

0.3 PREFACE

Please read the Operator Manual carefully. If you have any questions, please call the Plasmetrex service number +49-30 63 92 50 44.

For proper operation of Hercules® a sufficient RF grounding of the chamber wall is required !

The sensor should be located in the chamber wall above the wafer level in process position and not screened from by chamber parts, e.g., a liner. The measurement through ceramic window (ceramic liner) is possible if the gap between sensor electrode and ceramic is less than 0.1 mm and the ceramic is in contact with the plasma.

Please make sure that sensor and sensor cable are separated by at least 30 cm (1 ft) from the RF power cables to avoid electromagnetic interference.

Disassembling of Hercules system, sensor or sensor parts will void the warranty.

Please check the DC bias voltage / RF peak voltage measurement point and compare the Hercules® PMX value to the displayed value at the tool monitor.

Information concerning the Hercules® Viewer and the Hercules® LotViewer can be found in the corresponding manual.

**For further operations, refer to the Application Data Base
(<http://plasmetrex.com/adb/home.html>) and Application Guide
(<http://plasmetrex.com/ag/home.html>).**

Always disconnect power before opening the instrument or changing the fuse!

0.4 SAFETY AND HARDWARE



Note: Make sure all delivered parts match your order.

Caution: Make sure you disconnect the AC power cord prior to cleaning the Plasma Metrology System Hercules[®]. For cleaning, only use a lint-free cloth with Ethanol or DI water.

Technical Data:

- AC power input: 100 - 240 VAC
- Frequency: 50 - 60 Hz
- Power consumption: max. 250 W
- Main fuse: T2L/250 V, IEC 60127-2/III.

To change the fuse:

1. Turn off power and disconnect power cord from instrument.
2. The fuse is located in the fuse drawer at the power inlet. Pull out the drawer and replace the fuse, then re-insert the fuse drawer.

The central unit of the Plasma Metrology System Hercules[®] is a compact PCI system (see fig. 1 or 2).

Figure 1: The Plasma Metrology System Hercules[®] PMX

Figure 2: The Plasma Metrology System Hercules[®] C

1 Contents

1 Contents

0.1 LEGAL INFORMATION.....	2
0.2 WARRANTY.....	3
0.3 PREFACE.....	4
0.4 SAFETY AND HARDWARE.....	5
1 Contents.....	6
2 Overview.....	8
2.1 Hercules versions and their applications.....	8
2.2 Fundamentals.....	8
2.3 Characterization of RF Discharge.....	10
2.4 Plasmaphysical models for Hercules.....	11
2.4.1 SEERS - Self-excited Electron Resonance Spectroscopy.....	11
2.4.2 NEED - Nonlinear Extended Electron Dynamics.....	11
2.5 The Plasma Metrology System Hercules®	12
2.5.1 Determination of Plasma Parameters and their Influences on Tool and Process Parameters.....	12
2.5.2 Basic Setup of Plasma Metrology System Hercules®	14
2.6 The modular system of Hercules.....	15
2.7 Customized Sensors.....	16
3 Installation of Sensor and Hercules.....	17
3.1 Sensor Installation.....	17
3.2 Hercules Setup.....	17
3.3 Network connection.....	18
3.4 Software.....	18
3.5 Hercules® Master Graphical User Interface.....	19
4 Software Configuration	22
4.1 Start up Procedure.....	22
4.1.1 Sensor Installation.....	22
4.1.2 System Power-up.....	22
4.1.3 Start-up Procedure.....	22
4.1.4 The parameters of Hercules configuration.....	26
4.2 Troubleshooting Guide.....	29
5 Hercules® – Data Integration.....	31
5.1 file Name.....	31
5.2 Data Management.....	31

5.3 Equipment Coupling.....	34
5.3.1 LAM Plug and Play.....	35
5.3.2 ToolWeb.....	36
5.4 Hercules® Master with SECS/HSMS extension.....	36
5.4.1 Semiconductor Equipment Communication System.....	37
5.4.2 Basic setup: SECS extension.....	37
5.4.3 Main configuration of HSMS interface.....	37
5.5 Commands.....	37
5.5.1 Hercules® Equipment Constants.....	38
5.5.2 Data Tracing.....	39
5.5.3 Data Polling.....	40

2 Overview

2.1 Hercules versions and their applications

	Hercules PMX	Hercules C	Hercules N60	Hercules N100
Specific feature	With Bias measurement point for electron density		Only for 13.56 MHz	Up to 40 MHz
Main	Self Excited Electron Resonance Spectroscopy (SEERS)		Nonlinear Extended Electron Dynamics (NEED)	
Plasma/Discharge	Capacitive, inductive optional		Capacitive	
Input → Main Output	Full Fourier Spectrum of RF current incl. Resonance → e- collision rate → e- density (only PMX) → Fundamental		Lower harmonics, no resonance needed → e- collision rate → IonSheathRatio → Frequency	
Pressure depending on gas	P < 50 Pa		100 Pa < p < 1000 Pa	
Application	Etch and low pressure deposition (HDP PECVD)		Medium pressure, “classical” PECVD	

2.2 Fundamentals

This chapter describes the fundamental principles of a partially ionized, chemically reactive RF plasma discharges upon which the Plasma Metrology System Hercules® is based.

Plasma processing

Plasma based surface processes are indispensable for manufacturing very large-scale semiconductor integrated circuits (ICs) used in the electronics industry.

The RF plasma generates ions and etching or deposition species from the process gas in the chamber. The species impact with the surface layer (semiconductor). Reaction products are generated and pumped out. There is always a combination of physical and chemical reactions.

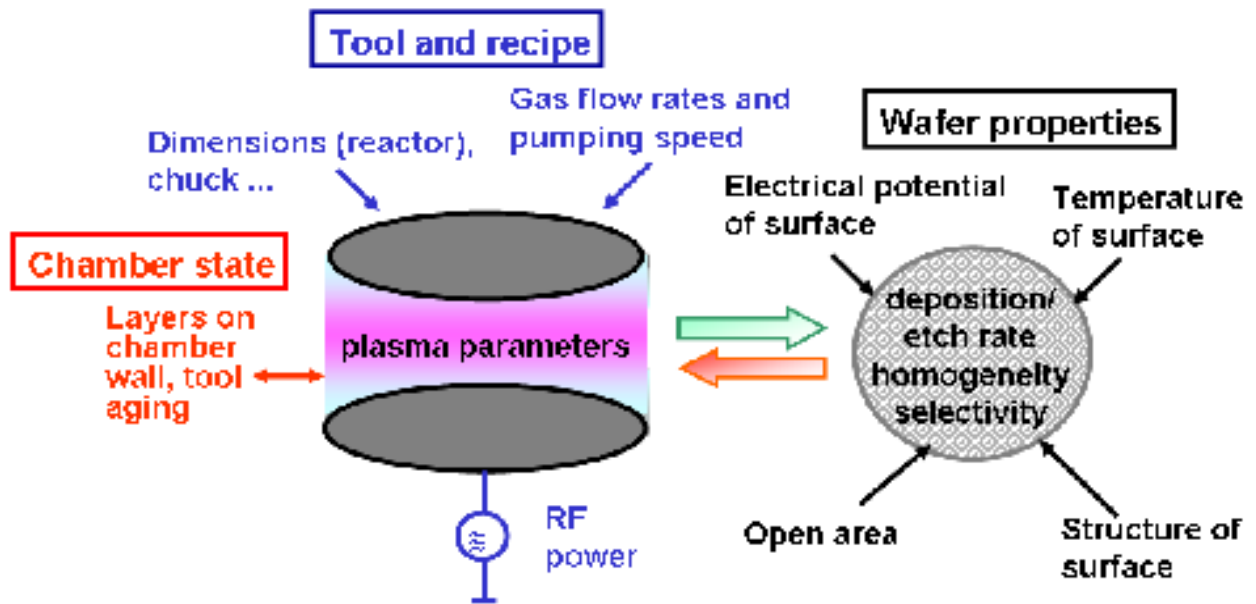

Figure 2.1: Influence of plasma parameters, tool, and recipe on chamber state and wafer properties

The wafer properties also affect plasma parameters. Many parameters (tool and recipe, wafer properties, and chamber state) interact. An unambiguous relationship is not possible for all plasma process steps.

2.3 Characterization of RF Discharge

Plasma

Plasma is often called the fourth state of matter. Plasma is a collection of free charged particles moving in random directions and is usually electrical quasi-neutral (see Figure 2.2). This state is characterized by a common charged particle density $n_e \approx n_i \approx n$ particles/cm³.

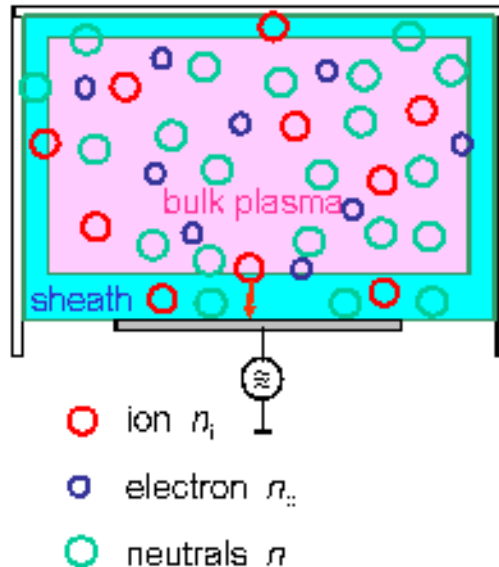

Figure 2.2: Schematic view of a plasma

RF discharge

The capacitive driven radio frequency (RF) discharge is commonly used for materials processing. However, the required processing (etching, deposition) of such discharges is generally the result of poorly understood physical and chemical processes, which occur in the gas phase and at the gas/solid interface. In this respect, the role of the sheaths in front of the electrodes is of fundamental importance for understanding the discharge physics of the asymmetrical capacitively coupled RF discharge. Due to their small mass (large mobility) and high temperature, the electrons strive to leave the bulk plasma. The sheath (dark space) keeps the electrons within the bulk plasma (shielding) by a retarding electric field build-up when electrons leave the outer regions of the plasma. The electrons-neutrals collisions take place in the bulk plasma where ions and electrons are created. The radicals for etching are formed in the bulk plasma. The ions move to the sheaths. The acceleration of ions provides energy for etching. This energy can be increased by external (RF) potentials.

2.4 Plasmaphysical models for Hercules

Using a hydrodynamic approach for the plasma bulk, the inert mass of the electrons can be treated as an inductance and the collisions with neutral particles, including power dissipation in the expanding sheath, as a resistance (see Figure 2.3).

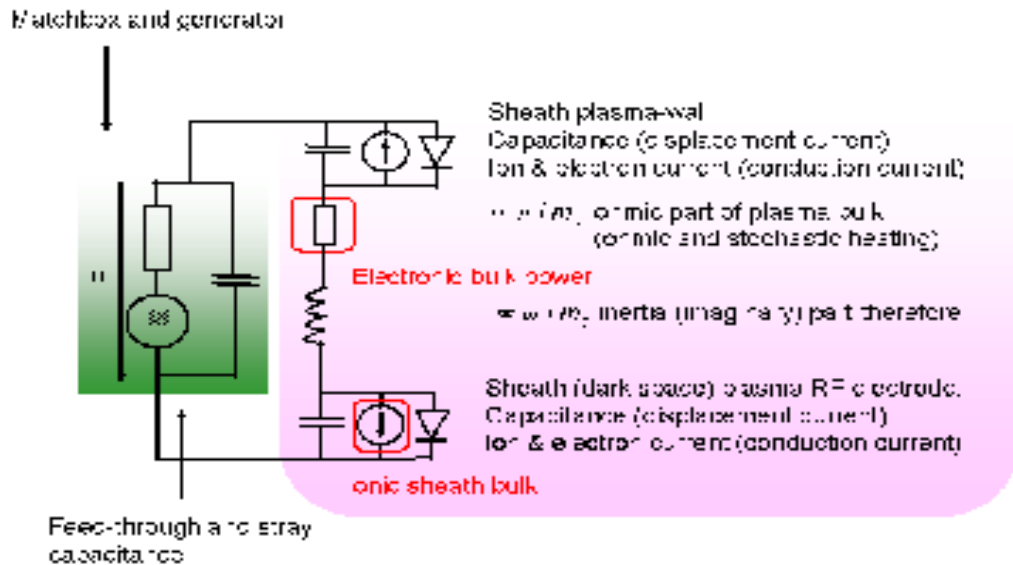

Figure 2.3: Equivalent circuit of the RF discharge

2.4.1 SEERS - Self-excited Electron Resonance Spectroscopy

Taking into account the capacitive behavior of the space charge sheath, the plasma can be described as a damped oscillator circuit. The nonlinear sheath capacitance excites the plasma by causing damped oscillations close to the geometric resonance frequency, which lies well below the plasma frequency (Langmuir frequency). For asymmetrical discharges and sinusoidal discharge, the current is known to be the sum of a saw tooth shaped part plus a damped oscillation (please see Jap. J. Appl. Phys. 36(1997), 4625-4631).

The Plasma Metrology System Hercules[®] PMX and C are based on the Self Excited Electron Plasma Resonance Spectroscopy (SEERS).

2.4.2 NEED - Nonlinear Extended Electron Dynamics

Whereas SEERS is mainly based on the occurrence of a resonance, NEED analysis the relation between to fundamental and the lower harmonics regarding their magnitude and phase relations. This requires a highly sophisticated plasma model including with the full set of the Maxwellian equations including finally also standing waves and the skin effect.

Advantages

The use of lower harmonics reduces the necessary RF bandwidth of the high speed digitizer and reduces so size and costs. It work also at higher pressure up to 10 Torr.

Disadvantages

The set of parameter it slightly reduces. A measurement of the electron density which is representative for the plasma bulk is possible.

2.5 The Plasma Metrology System Hercules®

2.5.1 Determination of Plasma Parameters and their Influences on Tool and Process Parameters

SEERS allows the determination of the volume-average electron plasma density n_e , the effective electron collision rate ν_{eff} , and the power dissipated by electrons in the plasma body P_B .



Note: Due to $1/n$ averaging, ranges of lower density get a higher weighting!

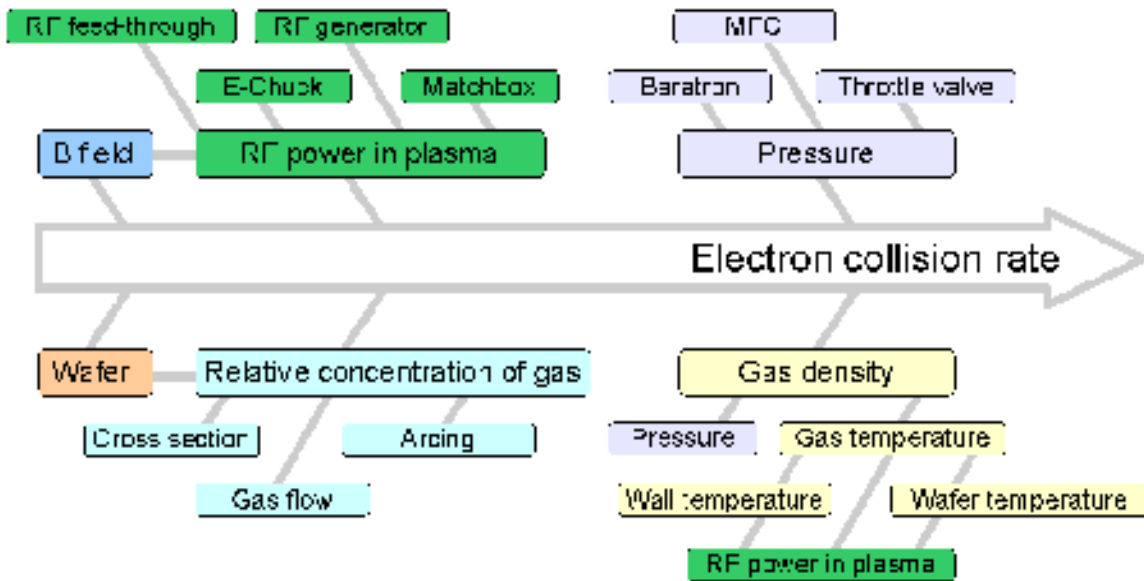

Figure 2.4: The influence of etch tool parameters on the electron collision rate

Electron collision rate

The collision rate of electrons ν_e (please see Figure 2.4) depends on:

- Power and pressure (recipe)
- Gas mixture (recipe)
- Impact of electrons on chemistry
- Feedback from chemistry via cross sections and relative concentration of species

and can be calculated for magnetic field $B = 0$:

$$\nu = \nu_{eff} \sim \nu_{stoch} + \frac{p}{kT_n} \left[\frac{p_1}{p} \sigma_1 \left(\frac{1}{\nu_e} \right) + \frac{p_2}{p} \sigma_2 \left(\frac{1}{\nu_e} \right) + \dots + \frac{p_n}{p} \sigma_n \left(\frac{1}{\nu_e} \right) \right] \nu_e$$

The stochastic heating is a collision less electron heating mechanism at the interface between bulk plasma and sheath. For weak magnetic field $B < 30$ G:

$$\nu_{orthogonal} = \nu_{parallel} \left[1 + \frac{\omega_{ce}^2}{\omega^2 + \nu^2} \right]$$

with $\omega_{ce}^2 = eB/m_e$

$\nu_{||} = \nu(B=0)$ → collision rate parallel to the B -field

ν_{\perp} → collision rate perpendicular to the B -field

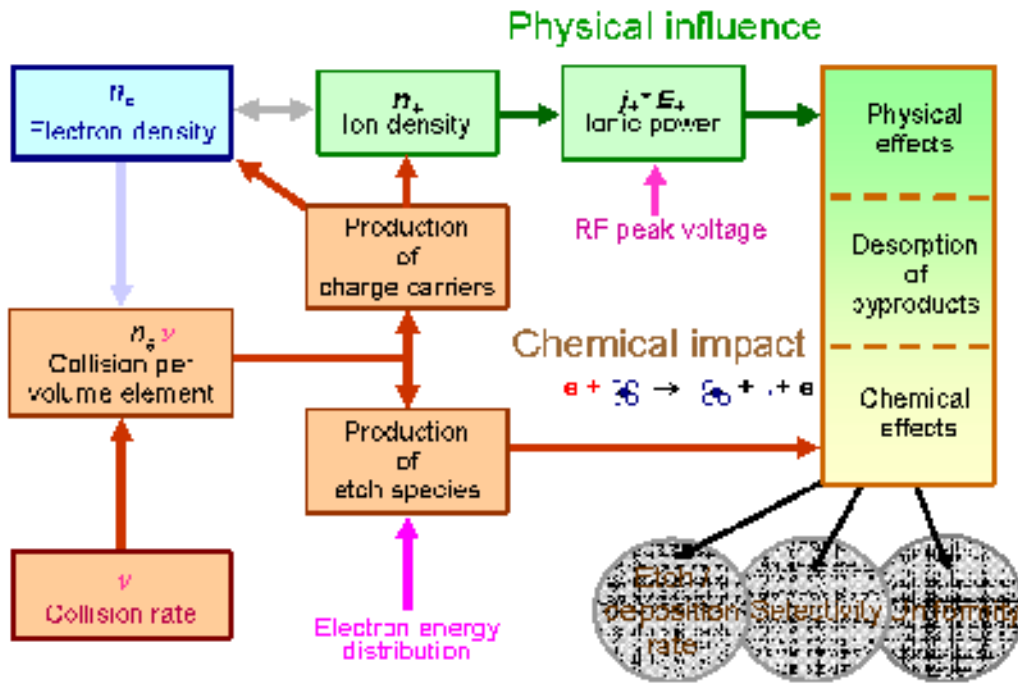

Figure 2.5: Influence of electron density and collision rate on the etch process

Electron density

For magnetically enhanced plasmas, the scaling law of electron density is given by

$$n_e \propto B_0^2 U_{peak}$$

Please see M. A. Lieberman, A.J. Lichtenberg, Principles of plasma discharges and materials processing, John Wiley & Sons, Inc., 2005.

Bulk power

The bulk power P_B is:

$$P_B = R_B \sum_k I_k^2$$

with I_k : harmonics of discharge (plasma current)
 R_B : plasma resistance

Plasma resistance

The plasma resistance R_B (ohmic part of the plasma bulk resistance) is:

$$R_B = \frac{\nu_{eff} m_e l}{e^2 n_e A}$$

with: n_e : electron density
 ν_{eff} : effective electron collision rate
 m_e : electron mass
 l : effective length of plasma (approx. electron gap)
 A : electron area

Note: The process window for each etch tool must be specifically defined. This is



due to the influence of the numerous parameters, e.g., RF power in plasma, pressure, B-field, wafer, relative concentration of gases, and gas temperature.

2.5.2 Basic Setup of Plasma Metrology System Hercules®

No calibration of Plasma Metrology System Hercules® needed!

The Hercules® sensor head is mounted flush to the wall of the chamber and must be properly grounded. The sensor does not affect plasma or process conditions. The Hercules® sensor measures a small component of the RF current. An insulating layer on the sensor can be treated as a large capacitance and adds a negligible serial impedance ($\ll 50 \Omega$). The current ratio of the measured current and the real discharge current is determined by the nonlinear model.

For further details visit <http://plasmatrex.com/sdb/home.html> or see the **Chapter 2**.

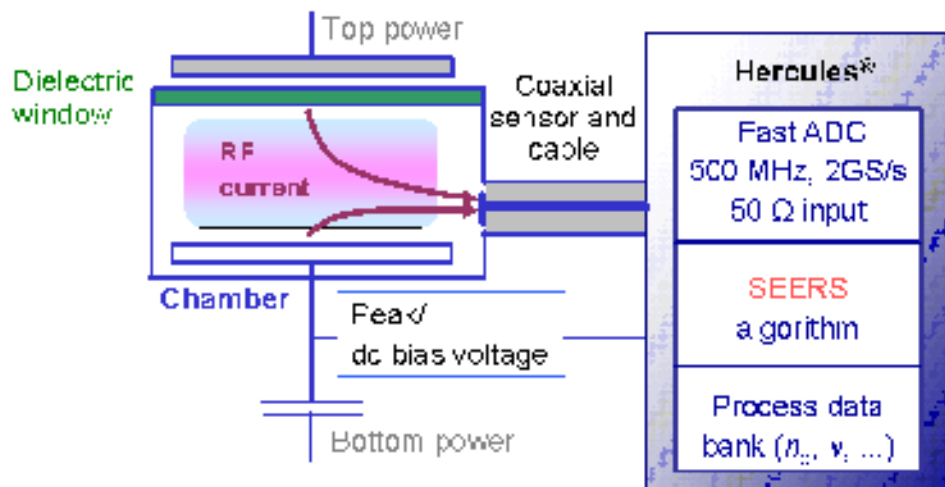

Figure 2.6: Basic setup

The Plasma Metrology System Hercules® provides a high temporal resolution, using a fast numerical algorithm. The RF peak voltage or DC bias voltage is measured by using a capacitive or resistive voltage divider, respectively.

Hercules® process performance

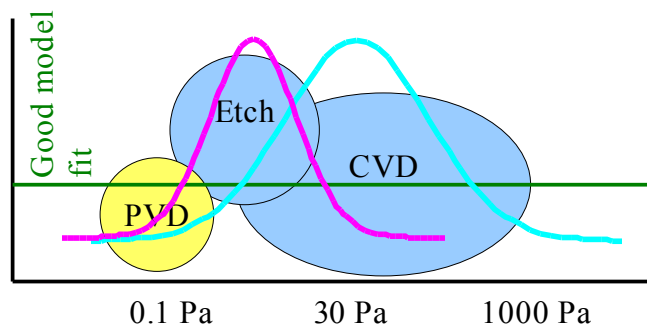

Figure 2.7: Hercules® process performance

Figure 2.7 shows the optimal pressure range in which the Plasma Metrology System Hercules® operates.

Please see <http://plasmatrex.com/principle.html>, [plasmametrology](http://plasmametrology.com) for more information about SEERS model.

2.6 The modular system of Hercules

The modular Hercules[®] Metrology System consists of

- Hercules[®] sensor, installed in the chamber wall.
- Hercules[®] measurement system (Hercules[®] PMX, C or N). It is a special hardware for the measurement of the RF sensor current and for the calculation of the plasma parameters. The system send the plasma data using the Modbus protocol to the master or to the fabwide APC system.
- Hercules[®] Master for configuration and visualization of plasma data with extensions for data storage and data transfer (different protocols: TOOLweb, SECS/HSMS). It can be installed on the Hardware of the Hercules[®] measurement system (it the system is used only for one chamber), on the Hardware extension of the measurement system, or on any other PC, connected with the Hercules[®] measurement system by network.
- Hercules[®] software for data analysis. The software (HercLotViewer for a big data amount and HercViewer for one lot) is a powerful tool for the analysis of the measured and stored data. It is usable for the analysis of data of the SAPC server, too.
- SAPC-Server for real time advanced data analysis (for more details see the SAPC server manual).

2.7 Customized Sensors

Customized sensors for special applications and/or special chambers are designed on request. The following information are needed:

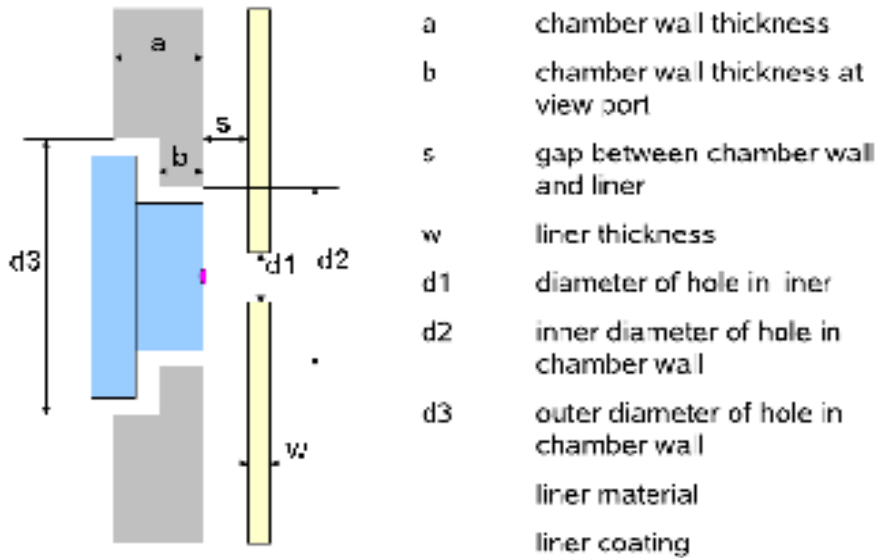

Figure 2.8: Chamber wall and liner

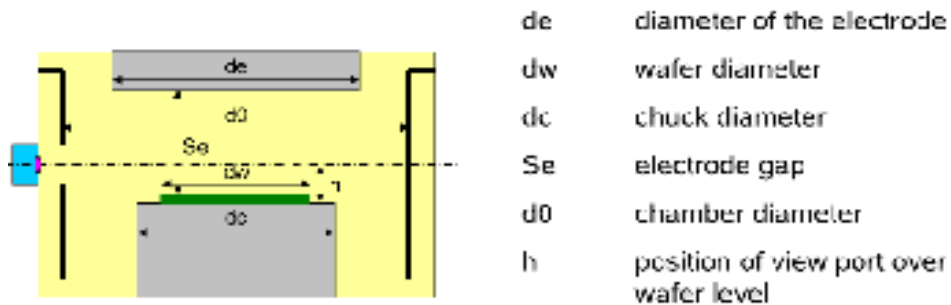

Figure 2.9: Chamber dimensions

Contact the Plasmatrix technical support for questions regarding custom sensors (<http://plasmatrix.com/contact.html>).



Note: The DC bias or RF peak voltage are used for electron density calculation, only for Hercules® PMX 500 or PMX 1000. For more information please see **Chapter 5 (Appendix).**

Should you have any queries, please contact the Plasmatrix service (<http://plasmatrix.com/contact.html>).

3.3 Network connection

The connection of the Hercules with network is recommended for the PMX and C system. If the master is running on a separate PC or is used for more Hercules systems the network connection is necessary. It is necessary for the N system, too.

3.4 Software



Note: Plasmatrix recommends to avoid the installation or usage of additional software on the Hercules system. The installation of additional software as an antivirus program or updates of the operating system - in particular if not authorized by Plasmatrix - leads to immediate loss of warranty.

Plasma Metrology System main program

The Hercules® main program is Herc_cxxxx or Herc_pxxxx. xxxx denotes the version number.

These executable files are always in the directory .

Configuration

The Hercules® Master (HercMaster_xxx) is provided for the Hercules® configuration. The detailed steps for the configuration are described in Chapter Start-up procedure.

Start of Hercules®

The Hercules® main program starts when the startup script “startherc.bat” is executed. The script must be modified after the software update.

Stop of Hercules®

A stop of Hercules® software or a communication problem between Hercules® and Hercules® Master is displayed by a button beside the sensor index at the Hercules® Master window.

Measurement

If Hercules® is running, the system is in an operating state. Hercules® generates plasma parameters as soon as the digitizer recognizes a signal from the sensor head. The plasma data are stored even when the plasma has been turned off for a specific time. This time is called the “plasma wait time.” The measurement itself is triggered by the plasma and there is no further need to interact with the system. The correct setting of the “plasma wait time” (time should be set in between the wafer exchange time and the duration of plasma less process steps) is essential for a correct storage of the plasma data. The plasma data will be stored in the Hercules® data files (*.hdx and *.hpl) if the plasma is turned off for a time longer than the plasma wait time. Hercules® will trigger on the event “wafer processed” only if there is a LAM R Plug and play sensor interface. In any case, the plasma data will be stored if the plasma is off for a time longer than the plasma wait time.

Software update

In case of a software update the executable files in the directory D:\herc\,

Herc_cxxxx.exe

HercMasterxxxx.exe

will be replaced by new versions. Furthermore the startup batch file “startherc.bat” is changed (overwritten).

The configuration of the main stream tools is stored in a xml-file in the D:\herc\directory. Directory. In case of overwriting the xml-file with an updated one, all self created configurations will be deleted. To avoid this, please save the old xml-file with a new name.

3.5 Hercules® Master Graphical User Interface

Hercules® Master for configuration and visualization of plasma data with extensions for data storage and data transfer (different protocols: TOOLweb, SECS/HSMS). It can be installed on the Hardware of the Hercules® measurement system (if the system is used only for one chamber), on the Hardware extension of the measurement system, or on any other PC, connected with the Hercules® measurement system by network.

If the Hercules® Master is installed at the Hercules Hardware it starts when the startup script “startherc.bat” is executed.

The following tabs are available at the Graphical User Interface (GUI):

Diagram shows plasma parameters.

Last Wafer indicates the progress of chamber conditioning.

Sensor Information gives additional information about the connected sensors.

Diagram

Please push the button “Show Diagram” to visualize the measured plasma parameter. If you disconnect the monitor please push the button “Show Diagram” again to switch off the visualization. This saves processor power.

One parameter (electron collision rate, electron density, DC bias/peak voltage, ...) can be selected independently at the display. The button under the diagram indicates the selected parameter (see Figure 3.2) with sensor index different sensor can be selected.



Note: If the Hercules® Master is connected to a Hercules® system while processing, there process data of the next process will be stored. That means after a time out of plasma wait time or process start. This ensures that only complete process will be stored.

Last Wafers

This viewer shows the processed and the current conditioning process (wafer) and provides an indication of conditioning state, drifts, and trends (see Figure 3.3).

Sensor Information

This tab shows only in case of sensor connection, the type, number, name version and IP address of the sensor(s) (see Figure 3.5).

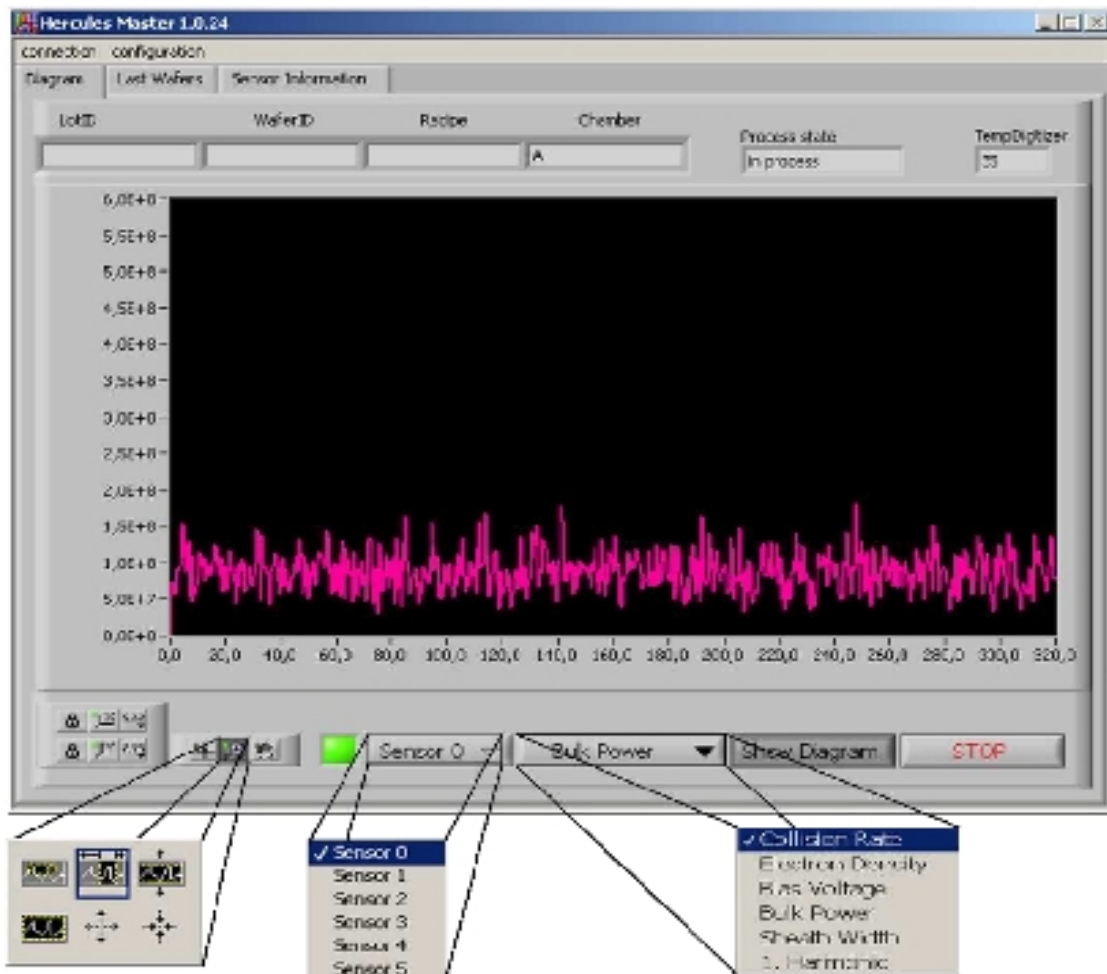

Figure 3.2: Graphical User Interface (GUI) of Hercules® Master

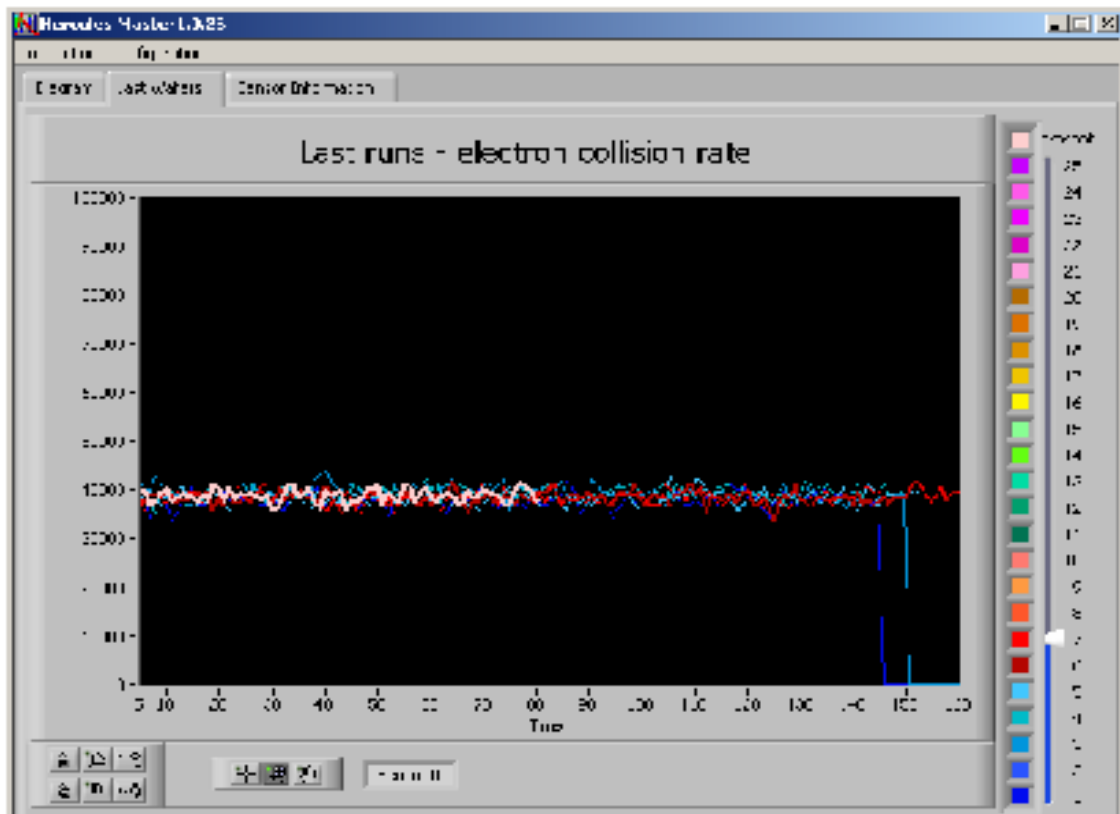

Figure 3.3: Graphical User Interface (GUI) of Last Wafers

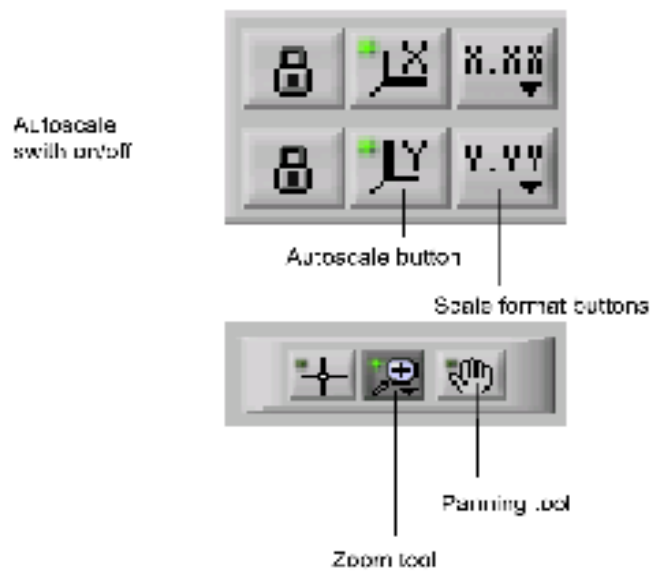

Figure 3.4: Scale options of diagrams

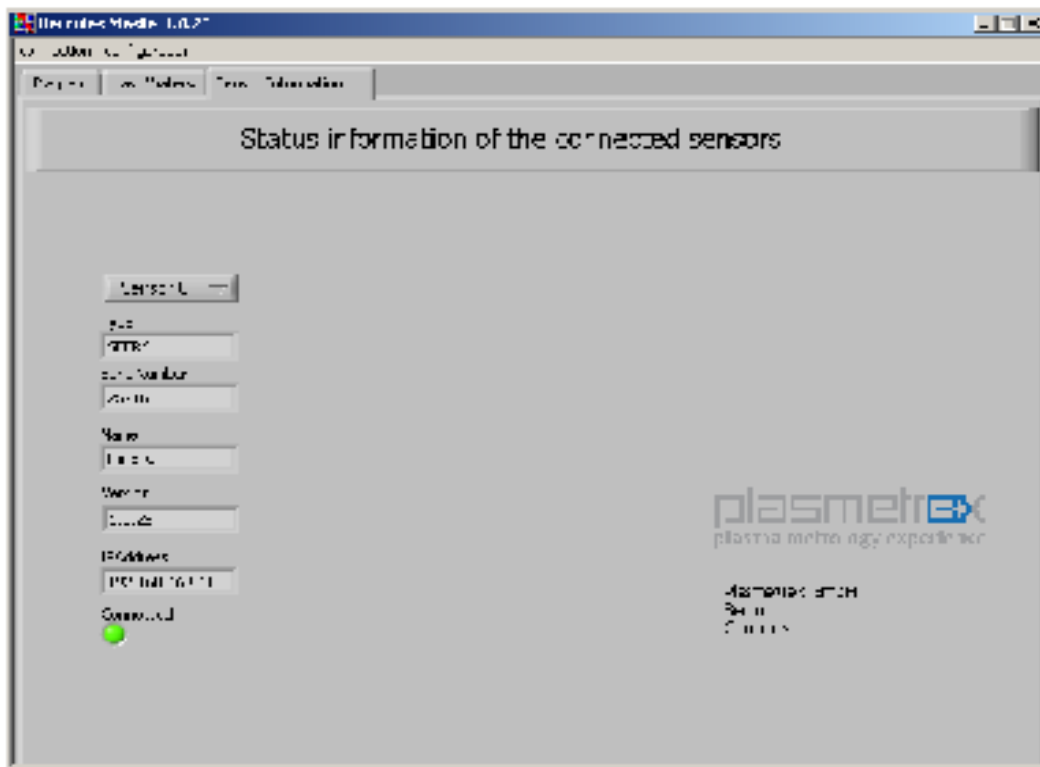

Figure 3.5: Sensor information

4 Software Configuration

4.1 Start up Procedure

4.1.1 Sensor Installation

Sensor head installation (see Chapter 1. and <http://plasmatrix.com/sdb/home.html>) should be performed during a preventive maintenance (wet clean).

4.1.2 System Power-up

The standard version of Hercules[®] does not include a monitor. It is up to the user to provide a suitable monitor before tuning on the system. The system is switched on by the green line switch located at the backside of the unit.



Note: Please take care that the power cable is protected by a special strain relieve for the AC power line plug.

4.1.3 Start-up Procedure



Note: first system start-up is normally performed by the Plasmatrix service engineer.

Step 1: Connection of Hercules[®]

Connection cable to of Hercules[®] system

- The AC power cable / power supplier
- Keyboard, monitor, if needed (PMX or C)
- A network cable (LAN 1), if available, necessary for N
- The sensor cable (on SMA input)
- Connect the bias measurement point and make sure to use the correct bias coefficient (see Table 5.1), only for Hercules[®] PMX.

Connect the Hercules[®] AC power plug into a tool outlet to avoid potential problems due to different ground potentials.



Note: Please take care that the power cable is protected by a special strain relieve for the AC power line plug.

The standard version of Hercules[®] does not include a monitor. It is up to the user to provide a suitable monitor before tuning on the system. The system is switched on by the green line switch located at the backside of the unit.

Step 2: Turn on Hercules[®] system

The Hercules[®] main program starts when the startup script “startherc.bat” is executed. The script must be modified after the software update.

Two users are already in the system. These are the “administrator” with the password left blank and

the “herculesuser” with the password “hercules.” Auto log-on is enabled to allow automatic start up of the system. Auto log-on will be disabled by pressing the shift key during the systems boot procedure. Auto log-on prompt will be displayed.

The system is equipped with USB keyboard with integrated trackball (optional). So the USB keyboard can be always removed or the system can generally run without. The Hwercules system runs without Keyboard and Mouse



Note: If run the user “herculesuser” the program starts automatically. In production mode the Hercules system must run as “herculesuser”. Only than after switch off – switch on the system will stats automatically.

Step 3: Start Hercules® Master software

The knowledge of the IP address of the Hercules® system is necessary for the configuration, if Master software is installed at the Hercules® system use IP address 127.0.0.1 (see Figure 4.1).

The Hercules® Master software HercMaster_ xxxx is a tool for the configuration up to six Hercules® system (chambers) of one etch or deposition tool. xxxx denotes the version number. This software can be installed at user defined PC or at the Hercules® system itself.

After start choose in the connection menu Figure 4.1.

Insert the IP address of the Hercules® system to connect with. The connection is indicated by a green button beside the sensor index.

The button show diagram opens a new screen where the current data are shown. The button sensor index allows to change between several sensors.

In the menu configuration the connected sensors can be chosen. The current configurations red out from the Hercules® systems are shown.

In the upper area the ConfigurationName (will be active in case of save a new configuration), the SensorName (delivered from the Hercules® system) and the Chamber (inserted manually) are shown.

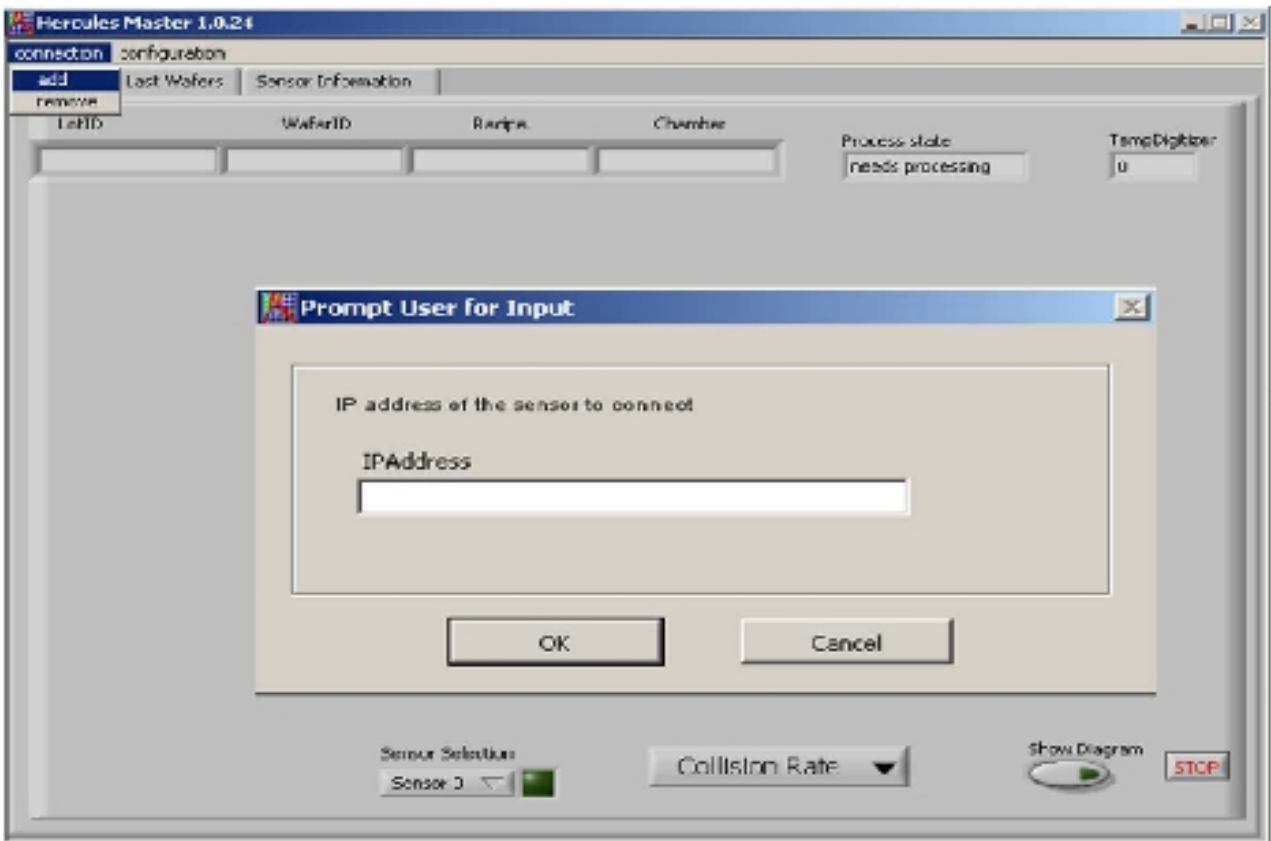

Figure 4.1: IP address

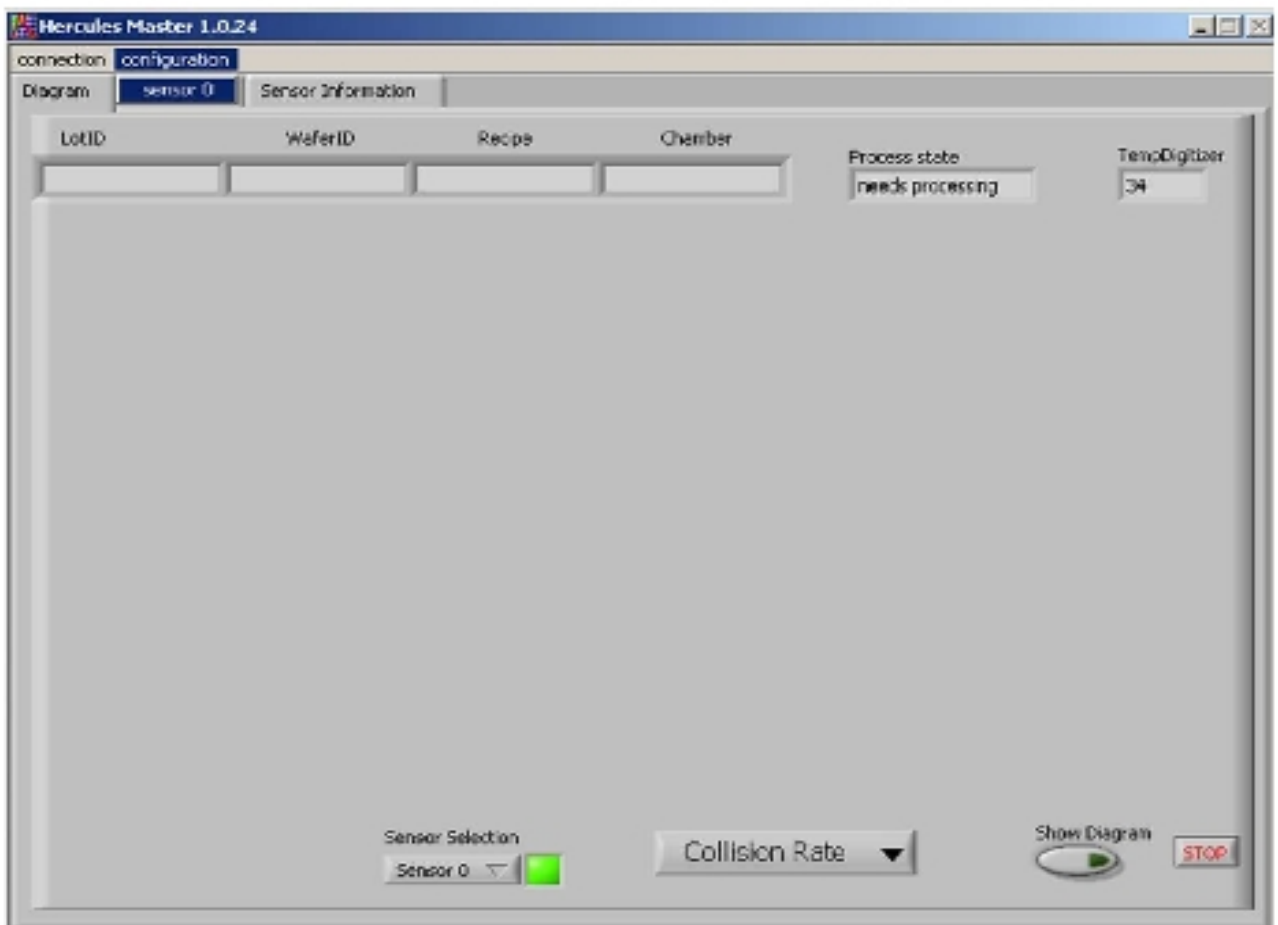

Figure 4.2: Selection of configuration

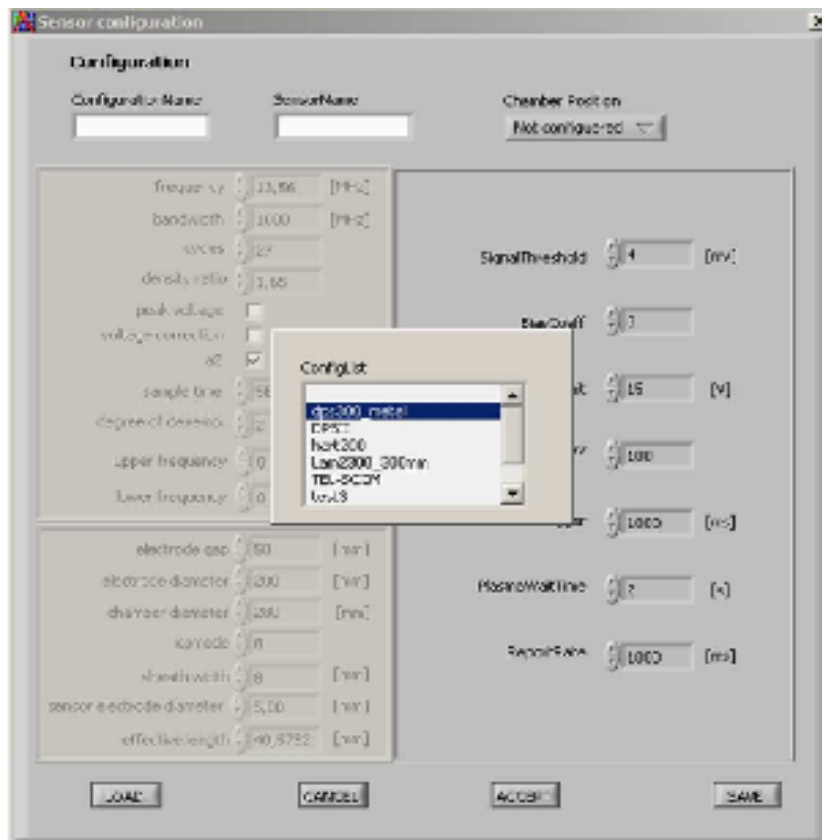

Figure 4.3: Selection chamber/tool from ConfigList

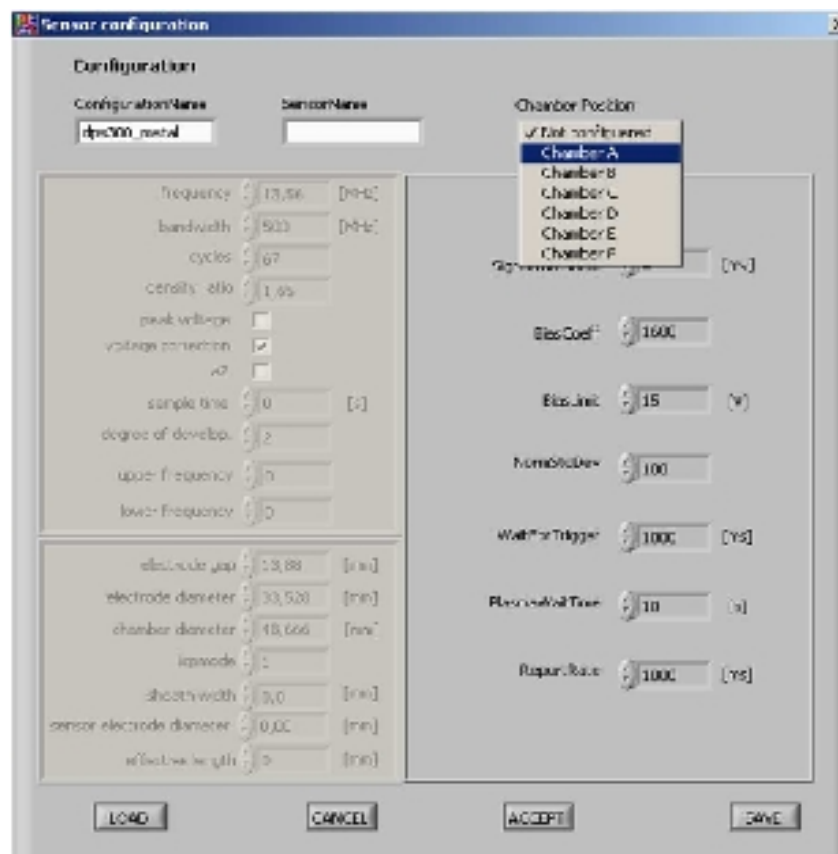

Figure 4.4: Selection of chamber A - F of the tool

4.1.4 The parameters of Hercules configuration

Parameter	Option	Comment
frequency		unit MHz
cycles		number of RF cycles, recommended: 27, should be adapted if 2f or 3f plasma
density ration		1.65 for electropositive plasma
peak voltage	off, on	for test point providing bias voltage: off default:off
voltage correction	off, on	for service only
a2		should be off, except icpmode = 0
sample time		for service only
degree of develop.		for service only
electrode gap		unit mm
electrode diameter		unit mm
chamber diameter		unit mm
icpmode	0, 1, 2	0: RIE (parallel plate) 1: TCP (coil on top insulator) 2: insulated chamber wall, no radial RF current see fig. 5.9 - 5.11
sheath width		unit mm mean sheath width if no DC bias / RF peak voltage is available
sensor electrode diameter		unit mm
effective length		for service only

Table 3.1: The parameters of Hercules configuration

Additional comments to the keywords

frequency:

frequency of the RF generator.

bandwidth:

the default value is 500 MHz. For generator frequency of 40 MHz or above the bandwidth should be set to 1000 MHz.

peak voltage:

if the system is connected to a RF peak voltage measuring point, set this keyword to ON.

electrode gap, electrode diameter, chamber diameter:

dimensions of the process chamber connected to Hercules® .

icpmode:

There are different types of RF power dissipation - capacitive and inductive. This leads to different chamber designs with different RF current distributions.

icpmode = 0:

RIE: Pure capacitive excitation with axial and radial RF current.

Examples for this mode: LAM® Rainbow, Applied Materials® E-MAX R , HART™ , SUPER-E™

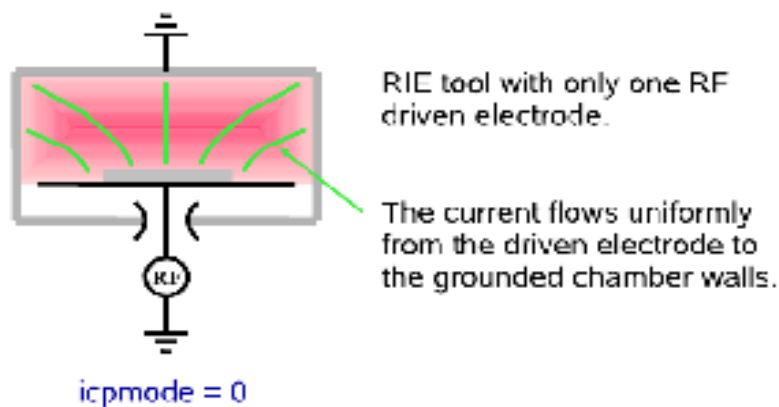

icpmode = 1:

ICP/TCP R : Additional inductive RF power dissipation on top of the chamber.

Examples for this mode: LAM R TCP® , Applied Materials® DPS I/II

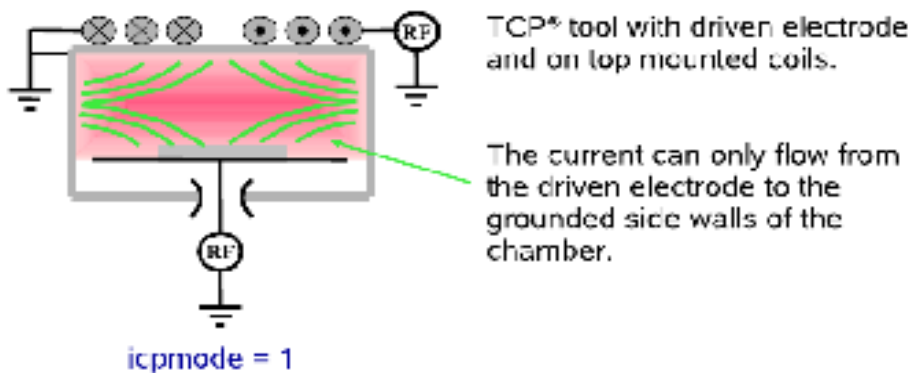

icpmode = 2:

ICP at side wall: In comparison to the RIE case additional inductive excitation at the (now dielectric / insulating) side wall. This results in a zero radial current at the dielectric side wall.

Example for this mode: Oxford Plasma Technology Plasmalab system 100, ICP 300

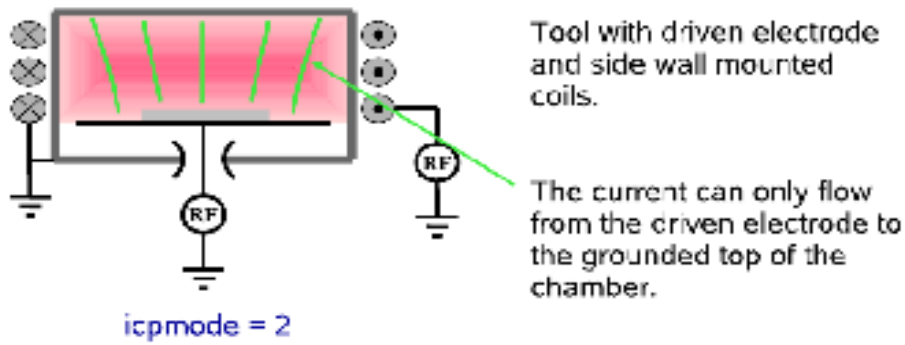

sheath width:

if neither DC bias nor RF peak voltage measuring point is available, the model requires a fixed width of the sheath (dark space, space charge sheath thickness). A virtual DC bias voltage is calculated, and will be displayed as DC bias voltage.

Please remember, this voltage is calculated from the discharge current only and is an estimated value.

Parameter	Option	Comment
SignalThreshold		unit mV
BiasCoeff		must be specified, ratio between real DC bias or RF peak voltage and measuring point voltage
BiasLimit		unit V, Limit of DC bias or RF peak voltage. If the DC bias or RF peak voltage is lower than the bias limit the system will measure with fix sheath width
NormStdDev		for service only
WaitForTrigger		unit ms
PlasmaWaitTime		unit s Time to wait after the plasma was switched off until data set (process) will be closed and saved, then waiting for new process. Must be higher than the plasma off time between steps and smaller than the plasma off time between two wafers.
ReportRate		unit ms

Table 3.2: The parameters of Hercules setup

Additional comments to the keywords

BiasCoeff:

only for Hercules® PMX, ratio of the DC bias / RF peak voltage and the testpoint voltage. This coefficient depends on the matchbox used with the plasma tool. The factor could be calculated from the known bias voltage of the tool.

Set the bias coefficient in the ini-file to 100 and start the Hercules® system. Click on the “extended” button and check the indicator of bias voltage. Divide the DC bias voltage obtained from the tool by the voltage indicated in the extended window. Then the result has to be multiplied with 100 and used as the new value for the bias coefficient. Set the BiasCoeff = 0 if DC bias / RF peak voltage is not available.

BiasLimit:

only for Hercules® PMX, if the measured DC bias or RF peak voltage is lower than the value set as “bias limit,” Hercules® calculates the bias from the fixed sheath (dark space, space charge sheath thickness). The sheath (dark space, space charge sheath thickness) is fixed by the parameter “sheath width.” This feature is useful in case of an additional RF excitation which is inductively coupled, e.g., TCP®. If the process runs without bottom power, no DC bias or RF peak voltage will appear and the RF peak / DC bias voltage will be calculated from fixed sheath width automatically.

PlasmaWaitTime:

indicates how many seconds the plasma process has to be off before the acquired data will be stored to disk and Hercules® will initiate a new measurement. The plasma wait time must be longer than the time of stabilization steps without plasma in the recipe and shorter than the plasma off time between two processes (wafer-wafer or wafer-dry clean).

Signal Threshold:

The signal threshold is the threshold for the plasma-on detection. It must be below the RF sensor current in plasma process and above the noise.

Please note the specific feature at some chambers like Novellus speed. The inductively coupled plasma at this tool always is on. Due to the RF frequency smaller than 5 MHz, the Hercules® can not calculate the plasma parameters. Only if the capacitive power is switched on, the Hercules® calculates the plasma parameters properly. Therefore the signal threshold must be higher than the sensor current for the base plasma (only inductive) and less than the sensor current of the plasma with capacitively coupled power.

4.2 Troubleshooting Guide

➤ The Hercules® system does not start and power on indicator (switch) and all LED's are off.

Check the following:

- The fuse is not blown
- The power switch is in the ON position
- The AC power cord is plugged into Hercules® system and a power outlet of the tool.

➤ Automatic login does not work.

If the last user was not herculesuser, the Hercules® system can not boot automatically!

In this case boot system manually and change to the user herculesuser ! Hold the shift key until the login window appears. Next time the system will boot regularly.

➤ Hercules® system does not detect plasma.

- Check signal threshold in the configuration
- Check fault code number at Hercules
 - 129 - Plasma off
 - 130 - Error in SEERS kernel
 - 134 - No trigger
- Check state of digitizer with front LED
 - slow blinking - wait for plasma (idle)
 - fast blinking - acquiring data
 - off - not working
- Check RF signal
 - Stop Hercules® software and start program “arqiris life”
 - Measure the RF current directly
- **Measured data are noisy.**
 - Make sure that the SMA connectors of the sensor.
 - Make sure that the sensor and the sensor cable are kept at a distance of at least 30 cm (1 ft) from the nearest RF power cable.
 - Check grounding (Different grounding point of Hercules® and tool?)
 - Check all other connectors, in particular RF connections
- **Measured data out of regular range**
 - Check the conFIGured parameters with Hercules® Master (diameters, frequency, signal threshold, chamber order, ...).
 - Check the sensor position in the chamber. The sensor should be located above the wafer and not be obstructed or covered by chamber parts.
 - If the data changed after PM, check chamber (used spare parts) again.
- **Hercules system is running slow**
 - Check the running programs
 - Check if additional software was installed (e.g., Antivirus protection software which needs a lot of CPU performance)

6 Hercules® – Data Integration

6.1 file Name

Standard file name format

The file *.hpl contains the raw data in a binary format. To access the data in the *.hpl file, a second file with the same filename and extension *.hdx is generated. For example, if the raw data file is 020306 cha.hpl, the corresponding hdx file will be named 020306:cha.hdx. This hdx file contains the pointers to the data of the hpl-file. Therefore, one set of data consists of the two files *.hdx and *.hpl. Both files are always needed for proper data analyses.

By default, file names are derived from current data and chamber number. For example, data created on March 6,2007 at chamber A would be stored in a corresponding hpl file 070306 cha.hpl.

Please note that dates are encoded as yymmdd.

file identifiers

If logistics as LotID and PPID (recipe) are transferred to the Hercules® system via SECS/HSMS or LAM’s PnP sensor interface, the data are saved lot-wise and the file name equals the LotID.

Example:

The current LotID is XY1234 and the process is running at chamber A. Therefore the pair of Hercules® files are XY1234 cha.hpl and XY1234 cha.hdx (see. Figure 6.1).

All drivers needed to run the additional hardware are installed in the directory d:/driver. It is not recommended to make any changes in this driver directory.

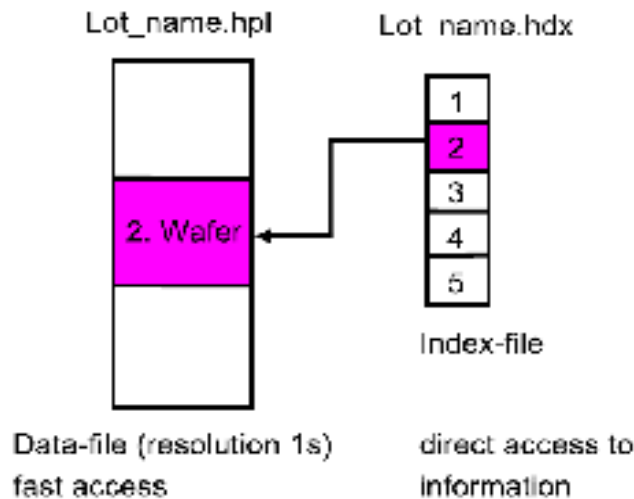

Figure 6.1: Pointer based format of Hercules® data

The update files will be provided by Plasmatrix in a zip file. Copy the zip file to the directory D:\herc and unzip the archive. Executing the batch file “update.bat” starts the update procedure.

6.2 Data Management

The Hercules® Plasma Metrology System without additional function measures the plasma para-

meter and provides process data. The native protocol for data transfer is Modbus/TCP according the SEMI standard E54.9. The data transfer to APC Systems as Maestria R is easy to handle via Modbus.

Other interfaces for data transfer are available:

- TOOLweb toolside
- LAM[®] Plug and play
- SECS/HSMS

An additional module enables the data storage in a file based data bank.

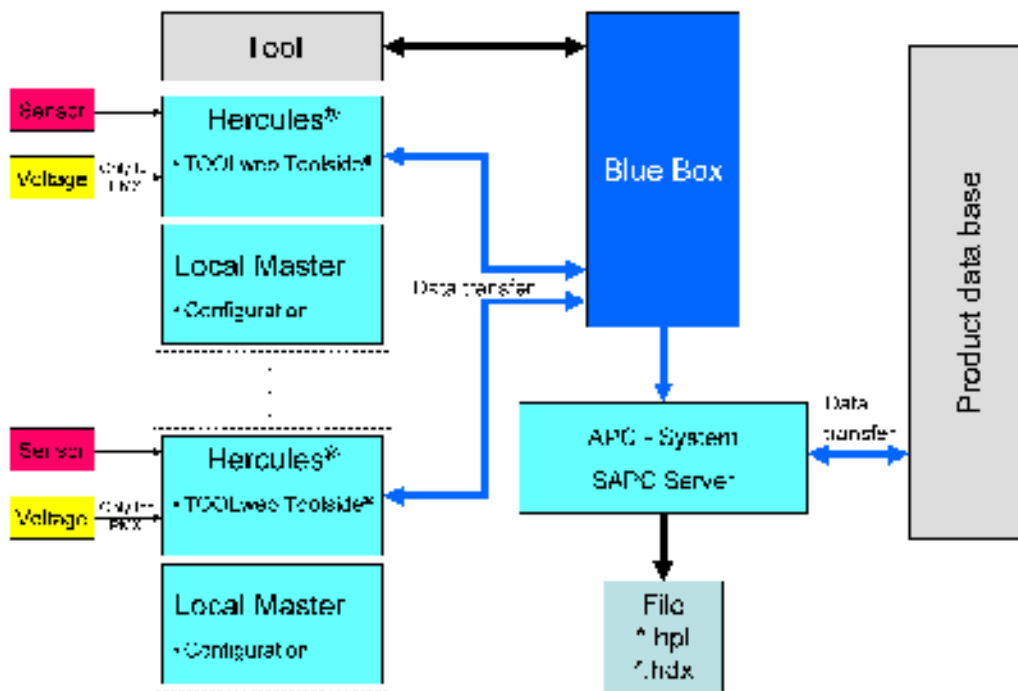

Figure 6.2: Hercules[®] setup with SAPC server is a local APC solution for data analysis and storage. The additional SPC module enables Statistical Process Control (SPC) capability by using of customer defined limits. The SAPC server can also provide data to any product data base using a customized data interface.

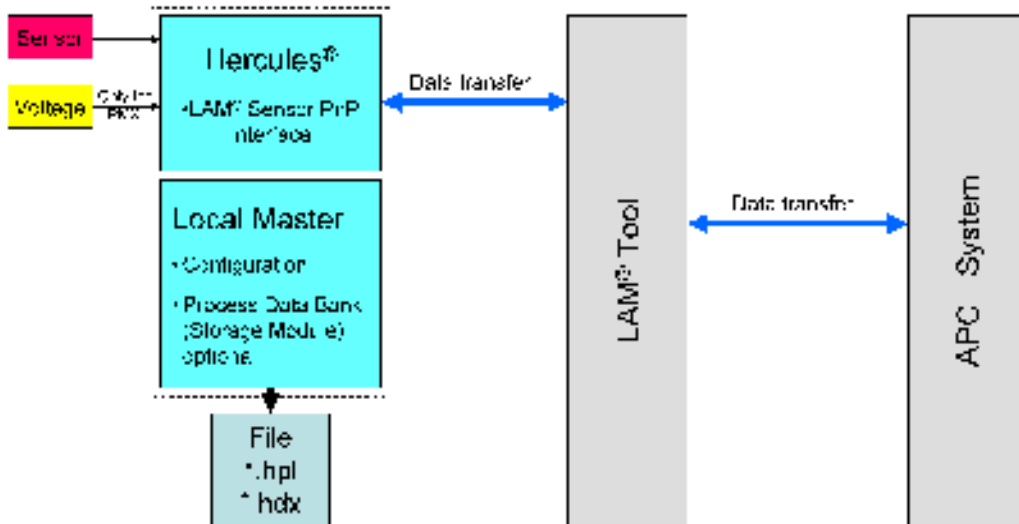

Figure 6.3: Setup of Hercules® data coupling via LAM R tool using Plug and Play interface.

Note: The so called Plug and Play sensor interface of the LAM R tool has to be activated by the LAM R service.

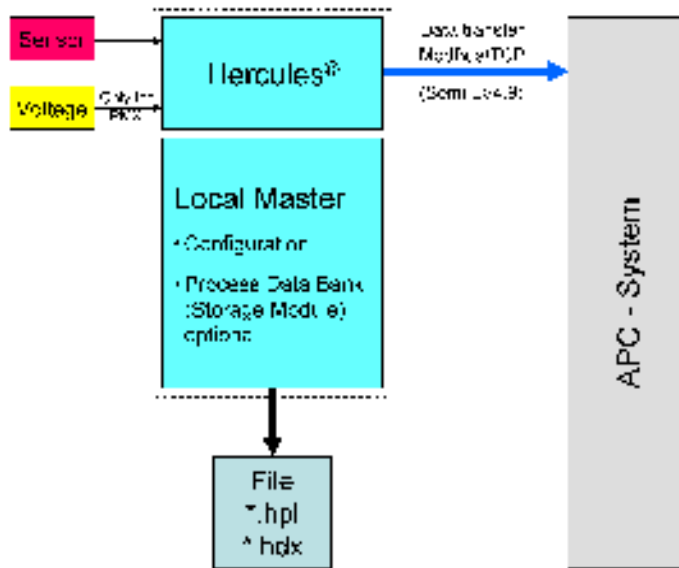

Figure 6.4: Basic Hercules® application with local Master for Hercules® configuration and data visualization. Additional data storage and SECS module as well as analysis software are available. For data transfer to the APC system, the Hercules® Master provides native Modbus/TCP according SEMI E54.9 standard.

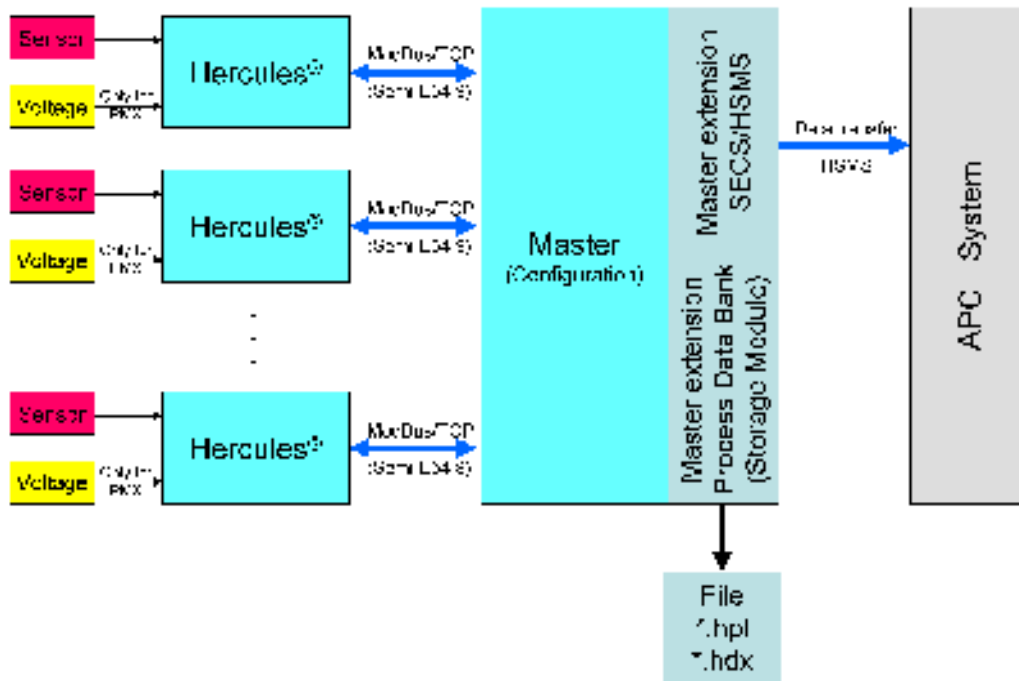

Figure 6.5: Hercules® multi chamber application. The Master has a user interfaces for configuration and data visualization. Additional data storage, SECS/HSMS, and analysis software modules are available. For the data transfer to APC system the Hercules® Master provides native Mod-bus/TCP according SEMI E54.9 standard.

6.3 Equipment Coupling

Equipment coupling enables the exchange of information between the plasma tool and the Hercules® system. This information includes the logistic data, such as:

- lotID
- waferID
- recipeID, etc.,

and the events such as:

- recipe start
- step start
- recipe end.

Due to the large amount of data generated in high volume production, equipment coupling is strongly recommended. An automatic analysis of the data is only possible if the lotID and/or recipeID are known.

Basic types of modules

Three basic types of modules for equipment coupling are as extension available:

- Interface based on the Semiconductor Equipment Communication Standard (SECS).
- TOOLweb TOOLside
- Plug and play sensor interface for LAM R 2300™ (Domino)



Note: It is necessary to have host applications. The native interface of the Plasma Metrology System Hercules® is Modbus /TCP (SEMI E 54.9).

6.3.1 LAM Plug and Play

The TCP/IP based interface provides a reliable means of transferring data between computing systems. The LAM R 2300™ creates a virtual circuit, a data path in which data blocks are guaranteed delivery to a target machine in the correct order. The computing systems within this virtual circuit are arranged as server system and client system. Both systems can send and receive messages. Messages are sent from the sender to the receiver until the receiver sends back a message stating that all the data blocks have been received in the correct order. Each server and client should have its own IP address to identify themselves in this virtual circuit and the server should specify a unique port number for establishing the communication.

In this communication configuration the generic sensor device operates as the client and the LAM R process module operates as server. Both the server and client run on separate computing processors with a unique IP address. The LAM R process module specifies a unique port number for this communication purpose. Both the LAM R process module and the generic sensor device are connected through the TCP/IP network. Once the generic sensor device is up and running, it sends a message requesting to be connected to the LAM R process module. After the connection is established, the server and client can now communicate using the predefined protocol. The synchronous command with reply is the chosen communication protocol for this configuration. The sender has an option to request an acknowledgment for the sent command message. If the sender expects a reply to the sent command message, the receiver has to reply with an acknowledgment message. If there is no reply to the sent command message within a reasonable time duration, e.g., five seconds, the same message will be sent again. After trying several times, e.g., 3 times, to send the same message and failing to receive a reply, the TCP/IP socket connection is considered interrupted. In this case, both the server and client may require operators action to reset their TCP/IP socket to be able to re-establish their connection. [For more details please contact LAM R Research Corporation]

The herc_c.ini

With the herc_c.ini the optional interfaces of the Hercules® C system can be conFigured.

```
herc_c.ini
[LAM P&P ]
IPAddress=192.168.168.244
Port=10001
[ToolWeb]
Port=80
```

Configuration of the ini-file "LAM P&P"

The network interface of the Hercules® system should be set to an IP address in the range 10.10.0.10 - 10.10.0.49 subnet mask 255.255.0.0.

Important! In the herc_c.ini the process module is defined were the Hercules® system is connected to.

```
PM1: PAddress=10.10.0.101
PM2: PAddress=10.10.0.102
PM3: PAddress=10.10.0.103
PM4: PAddress=10.10.0.104
```

The IP address range of the Hercules® system is 10.10.0.11 ...29, Subnetmask=255.255.0.0

6.3.2 ToolWeb

The port number for the ToolWeb interface must be set in the her_c.ini (see above). Afterwards this port number and IP address of the Hercules® C have to set at the BlueBox (see Bluebox manual).

6.4 Hercules® Master with SECS/HSMS extension

The Hercules® Master controls the subnetwork of Hercules® sensor systems. The standard communication protocol between Master and Hercules® sensor systems (data producer) is Modbus/TCP according to SEMI 54.9. The function codes for reading and writing registers are also supported.

Basic functions of Hercules® Master:

- GUI (Graphical User Interface) for configuration of Hercules® Sensors.
- Visualization of the measured data of connected Hercules® Sensors.

Options:

- **HSMS interface:** The HSMS/SECSII interface enables the data exchange with the Fab Host. It provides logistical data (Lot Id, Wafer Id, recipe etc.) from the host to the sensor and sensor data (plasma parameter) to the host. This option can be also used for the connection of Hercules® with a Fab-wide FDC/SPC or APC solution.
- **Process Data Base:** Beyond the visualization of the data sensor, they are stored in a le based data base. The sensor data can be selected by the logistical data (if available). This option includes HercViewer and HercLotViewer license. The HercViewer is designed for a detailed lot analyzes whereas the HercLotViewer can handle also the data of hundreds of lots for visualization and analysis.

The Master software searches after program start the ini-file for Sensor . If a valid setting with an IP address is found a connection at the port 501 is initiated. Then the master is setting the chamber position from the ini-file.

ChamberPosition=A or ChamberPosition =1
ChamberPosition=B or ChamberPosition =2
ChamberPosition=C or ChamberPosition =3
ChamberPosition=D or ChamberPosition =4
ChamberPosition=E or ChamberPosition =5
ChamberPosition=F or ChamberPosition =6

The identifier of the sensor in the ini-file is in ascending order and starts with A.

Example for herc_master.ini

```
[SECS]
RemoteIPAddress=128.0.0.1
RemotePort=5000
LocalPort=3000
[Sensor 0]
IPAddress=127.0.0.1
ChamberPosition=A
[Sensor 1]
IPAddress=192.168.168.121
ChamberPosition=B
```

6.4.1 Semiconductor Equipment Communication System

The additional Master extension enables the exchange of data between Hercules® and SECS (Semiconductor Equipment Communication System) host through a set of SECS messages. The plasma data obtained by the Hercules® Plasma Metrology System are linked to the logistic information of the processed wafer. The quality of the data analysis increases due to the lot, wafer, or product selection. The Master extension SECS is not a 100% SECS implementation and supports only the commands listed below.

6.4.2 Basic setup: SECS extension

The SECS extension is able to communicate via TCP/IP connection (HSMS). It has to be configured by editing the file `herc_master.ini` which should exist in the same directory as the `HercMaster` executable.

6.4.3 Main configuration of HSMS interface

The HSMS interface supports the alternating connection mode as described in SEMI E37. It is only necessary to configure IP address and TCP port number.

If the host is active the parameter "LocalPort" has to be set. The host shall try to connect on this port and the IP address of the system on which the Master is running.

If the host is passive RemoteIPAddress and RemotePort have to be set. The connection will be initiated by the Master in this case using these parameters.

Here an example of the SECS section of the `herc_master.ini` file:

```
[SECS]
RemoteIPAddress=127.0.0.1
RemotePort=5000
LocalPort=3000
```

6.5 Commands

The SECS extension can establish communication using HSMS or SECS I. The protocol is set through the ini-file.

The logistic information of the processed wafer will be transferred by setting equipment constants in terms of S2F15.

Supported commands:

S1F1, S1F3, S1F11, S1F13, S2F15; S2F23, S2F31

Hercules® initiated commands:

S6F1, S1F1

Examples:

a) S1F1 command - Heartbeat control

```
S1F1 W/*Host → Hercules*/  
S1F2 W/* Hercules → Host */  
<L[2]  
<A“HercPL”>  
<A“C2.001”>>.  
S1F13W/*Host → Hercules*/  
S1F14  
<L[2]  
<U10>  
<L[2]  
<A“HercPL”>  
<A“C2.001”>>>.
```

b) S2F15 command - Transfer of logistics

```
S2F15 W/*Host → Hercules*/  
<L[6]  
<L[2]  
<U2[1] 2000> /*LotID Chamber C*/  
<A[12]’D012080-0300’>  
>  
<L[2]  
<U2[1] 2001> /*WaferID Chamber C*/  
<A[13]’91431CTF159C0’>  
>  
<L[2]  
<U2[1] 2002> /*PPID Chamber C (recipe)*/  
<A[11]’RST R 309AAAC’>  
>  
<L[2]  
<U2[1] 2003> /*Recipe Step Chamber C*/  
< A[18] ’022000100212254163’> /*RecipeStep+<TIMESTAMP>*/  
>  
<L[2]  
<U2[1] 2005> /*ToolID*/  
<A[4] ’ET10’>  
>  
<L[2]  
<U2[1] 2006> /*Hours since last wet clean*/  
<A[3]’112’>>>.
```

6.5.1 Hercules® Equipment Constants

The equipment constant (EC) is given by the chamber number and the corresponding parameter. The EC is calculated from the ChamberNumber (beginning with 0) *1000+ParameterNumber.



Note: In case of P5X00 (APPLIED MATERIALS R),e.g., Chamber A gets the ChamberNumber 0.

The following ParameterNumbers are possible:

- 0: LotID
- 1: WaferID
- 2: PPID (recipe)
- 3: Recipe Step
- 4: Recipe End (version 2.1.14)
- 5: ToolID
- 6: RF-hours since last wet clean

See example above:

ECV:2002 - PPID Chamber C (Hercules' Chamber number =2)

ECV:0 - LotID Chamber A

The Recipe Step should be sent on the event "Recipe Step has changed". The format is ASCII based:

The Recipe Step as A[2] and <TIMESTAMP> as A[16] defined in SEMI standard (no delimiter).

For example '022000090212254163': The Recipe Step has changed into step 2 on Sep. 2, 2000; 12:25:54.163.

If no timestamp is available, <TIMESTAMP>='0000000000000000':



Note: If the timestamp is available, the clocks of the Hercules® system and the host can be synchronized using S2F31 command. Please take care that the synchronization will not initiated during a process or an active measurement on the Hercules® respectively.

6.5.2 Data Tracing

Hercules® sends data to the host system when a data trace was initialized using S2F23. Only one trace for each chamber can be initialized. Four status variables (SV) exist for each chamber. The data-sampling period should not be longer than five seconds. The report group size is always one. $SVID = ChamberNumber * 1000 + ParameterNumber$

ParameterNumber:

- 100:collision rate [s-1]
- 101:electron density [cm-3]
- 102:bias/peak voltage [V]
- 103:rf current [A]
- 104:sheath width [cm]

S2F23 W

<L,5

<U40>

<A'000010'>

<U4 R 20>

<U41>

<L,4

<U4 2100> /*collision rate chamber C*/

<U4 2101> /*electron density chamber C*/

```
<U4 2103> /*bias/peak voltage chamber C*/  
<U4 2104> /*bulk power*/  
>  
>
```

S2F24

```
<B0>.
```

Error codes of the S2F24 command:

0 - OK

1 - Number of SVID greater than four

2 - TRID for this chamber already exists

3 - DSPER > 5 s

4 - Error in S2F23 command,

If Hercules® receives unknown streams and functions, it will respond with the corresponding S9-function.

6.5.3 Data Polling

Data can be requested by the SECS command S1F3. The maximum number of SVID is 20, i.e., 5 parameters per process chamber.

Example:

S1F3W

```
<L,2
```

```
<U4 100>, collision rate chamber A
```

```
<U4 103>, rf current chamber A
```

```
>.
```

S1F4

```
<F4 123456.8>
```

```
<F4 2.34>
```

```
>.
```